

POLYPRO GEN²

NEW!

NEXT GENERATION POLYPRO ADHESIVE



COMPLIES WITH
AS 5216:2018
FOR
POST-INSTALLED
FASTENINGS



TECHNICAL MANUAL

TDS 2022.1

BIS-P GEN2



**PolyPRO Injection System with
ETA Assessment
Option 1 for Cracked and
Non-Cracked Concrete.
AS 5216 Compliant**



Use Conditions

- Static and quasi-static loads: Threaded rod M8 to M24, Rebar Ø 8 to Ø 25
- Seismic action for performance category C1: Threaded rod M8 to M16*
- Seismic action for performance category C2: Threaded rod M12 to M16*
- In Reinforced or unreinforced, Cracked and Non-Cracked Concrete Strength classes C20/25 to C50/60
- In Dry, Wet & Flooded Holes
- Structures subject to dry internal and permanent damp internal conditions.
- Structures subject to external atmospheric exposure.
- Overhead Installation allowed.

*except hot-dip galvanized rods

Typical Applications

- Infrastructure Construction (Roads, Viaducts, Sound Barriers, Crash Barriers, Harbours, High Rise Construction, Steel Construction)
- Production Facilities (Installation of Cranes, Robots, Conveyer Lines etc.)

Approvals & Test Reports

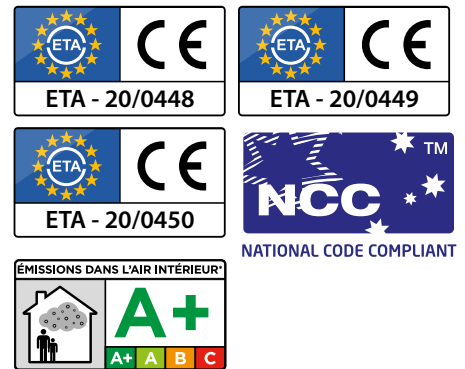

Temperature Range

B+BTEC BIS-P GEN2 injection mortar may be applied in the temperature ranges given below. An elevated base material temperature leads to a reduction of the bond resistance.

Max. long term base material temperature: Long term elevated base material temperatures are roughly constant over significant periods of time.

Max. short term base material temperature: Short term elevated base material temperatures are those that occur over brief intervals, e.g. as a result of diurnal cycling.

Temperature Range	Temperature Base Material	Max. Long Term Base Material Temperature	Max. Short Term Base Material Temperature
Temp. Range I	-40°C to +40°C	+24°C	+40°C
Temp. Range II	-40°C to +80°C	+50°C	+80°C

THREADED RODS



Suitable Anchor

Rods M8 - M24

- Steel 5.8 and 8.8 Zinc Plated, Hot Dip Galvanized or Sherardized
- Stainless Steel A2 and A4
- High Corrosion Resistant Steel 1.4529 and 1.4565

Installation Procedures

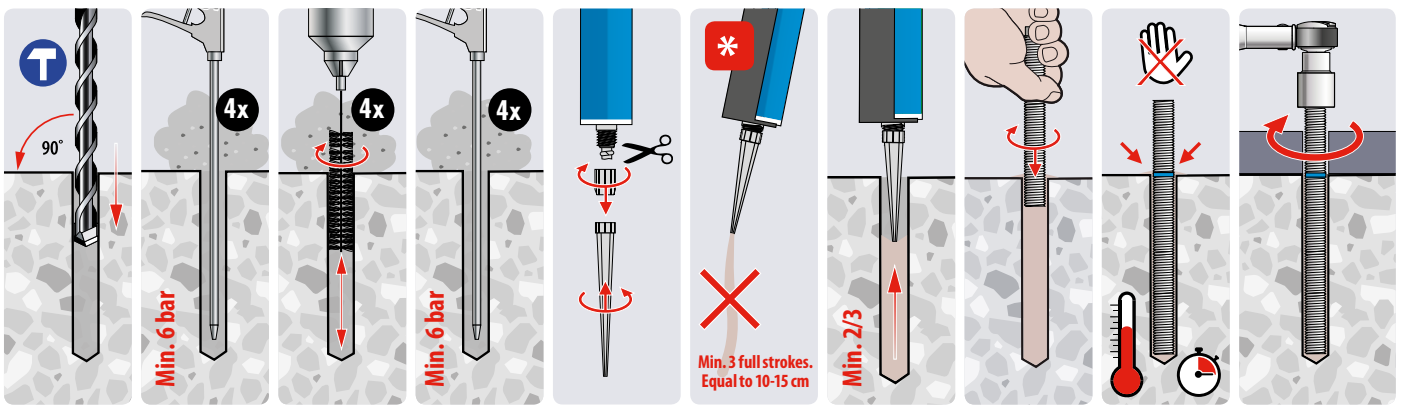

Curing Times¹⁾

Temperature ²⁾	-5°C to -1°C	+0°C to +4°C	+5°C to +9°C	+10°C to 14°C	+15°C to +19°C	+20°C to +29°C	+30°C to +34°C	+35°C to +39°C
Working Time	90 min	45 min	25 min	20 min	15 min	6 min	4 min	2 min
Curing Time	6 h	3 h	2 h	100 min	80 min	45 min	25 min	20 min

1) Cartridge Temperature must be between +5°C and +40°C. 2) Concrete Temperature



Specification Data for the use in Cracked and Non-Cracked Concrete and Hammer/Air Drilled Holes according to EAD 330499-01-0601 and AS 5216:2018

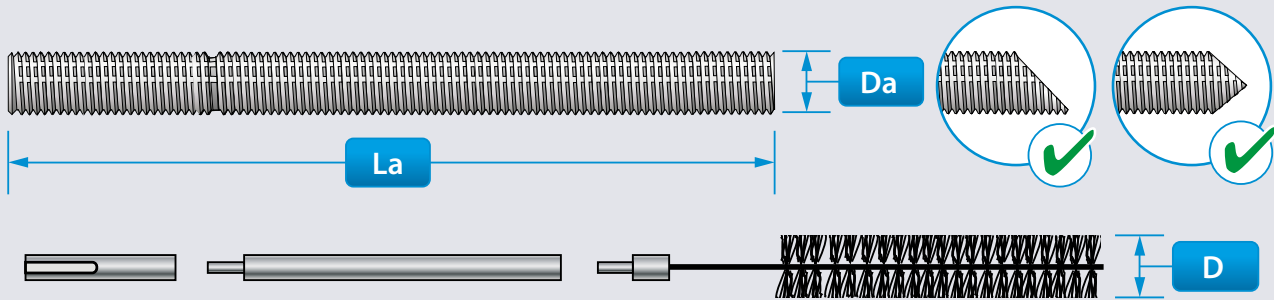

Installation Dimensions

Anchor Size	D _a		M8	M10	M12	M16	M20	M24
Anchor Rod Length	L _a	[mm]	110	130	160	190	260	300
Min. Eff. Anchorage Depth	h _{ef, min}	[mm]	60	60	70	80	90	96
Max. Eff. Anchorage Depth	h _{ef, max}	[mm]	160	200	240	320	400	480
Anchorage Depth for Calculation	h _{ef, calc}	[mm]	80	90	110	125	170	210
Hole Diameter	d _o	[mm]	10	12	14	18	24	28
Diameter Clearance Hole in Fixture								
Prepositioned installation	d _f	[mm]	9	12	14	18	22	26
Push through installation	d _f	[mm]	12	14	16	20	24	30
Max. Fixture Height	T _{fix} ≤	[mm]	20	30	35	45	70	65
Recommended Torque ¹⁾	T _{inst} ≤	[Nm]	10	20	40	80	120	160
Required Volume per cm Embedment Depth	V _s	[ml/cm]	0,44	0,59	0,75	1,09	2,25	2,87

1) Max. recommended torque moment to avoid splitting failure during installation with minimum spacing and edge distance

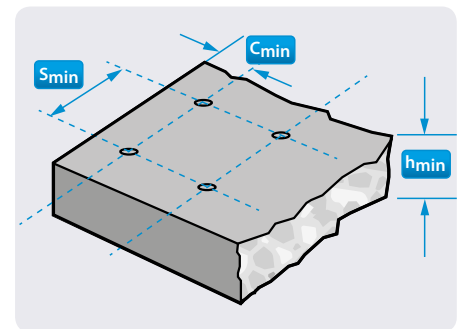
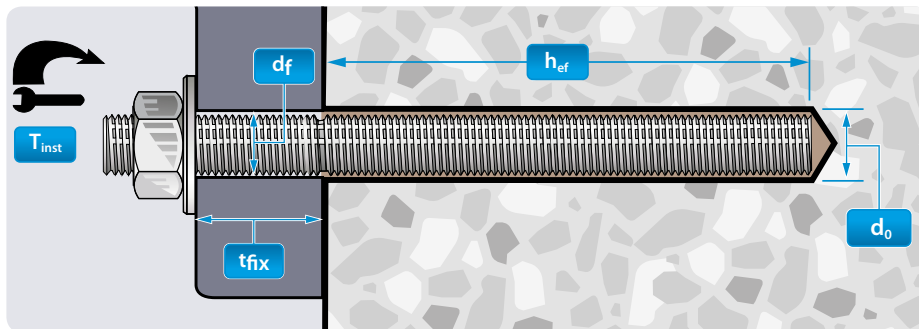

Member Thickness, Edge Distance & Spacing

Anchor Size	D _a		M8	M10	M12	M16	M20	M24
Min. Member Thickness	h _{min}	[mm]	h _{ef} + 30 mm ≥ 100 mm			h _{ef} + 2d _o		
Min. Edge Distance	c _{min}	[mm]	40	50	60	80	100	120
Min. Spacing	s _{min}	[mm]	40	50	60	80	100	120

Steel Brush Dimensions

Anchor Size	D _a		M8	M10	M12	M16	M20	M24
Brush Diameter	D	[mm]	12	14	16	20	26	30
Min. Brush Diameter	D _{min}	[mm]	10,5	12,5	14,5	18,5	24,5	28,5

Static and quasi-static resistance (for a single anchor)

All data in this section subject to:

- Correct setting (see setting instructions).
- No edge distance and spacing influence.
- Standard embedment depth ($h_{ef,calc}$), as specified in the 'Installation Dimensions' table.
- Concrete C20/25, $f_{ck} = 20 \text{ N/mm}^2$.
- Temperature range I: (max. long/short term temperature +24°C/+40°C).
- Shear loads are calculated without the influence of a lever arm.
- $\psi_{SUS} = 1,0$ according EN 1992-4:2018; eq. 7.14a.
- Recommended loads are with overall partial safety factor for action $\gamma_G = 1,4$. The partial safety factors for action depend on the type of loading and shall be taken from national regulations.



Steel Decisive

Design Resistance Dry/Wet Concrete & Flooded Holes

Non-Cracked Concrete		D_a		m8	m10	m12	m16	m20	m24
Steel 5.8	Tensile	N_{Rd}	[kN]	9,5	12,6	18,4	27,9	47,5	70,4
	Shear	V_{Rd}	[kN]	8,8	13,6	20,0	37,6	59,2	84,8
Steel 8.8	Tensile	N_{Rd}	[kN]	9,5	12,6	18,4	27,9	47,5	70,4
	Shear	V_{Rd}	[kN]	12,0	18,4	27,2	50,4	78,4	112,8
A4-50	Tensile	N_{Rd}	[kN]	6,3	10,1	14,7	27,6	43,0	61,9
	Shear	V_{Rd}	[kN]	3,8	6,3	8,8	16,4	25,6	37,0
A4-70	Tensile	N_{Rd}	[kN]	9,5	12,6	18,4	27,9	47,5	70,4
	Shear	V_{Rd}	[kN]	8,3	12,8	19,2	35,3	55,1	79,5

Cracked Concrete		D_a		m8	m10	m12	m16	m20	m24
Steel 5.8	Tensile	N_{Rd}	[kN]	5,0	7,1	10,4	15,7	--	--
	Shear	V_{Rd}	[kN]	8,8	13,6	20,0	37,6	--	--
Steel 8.8	Tensile	N_{Rd}	[kN]	5,0	7,1	10,4	15,7	--	--
	Shear	V_{Rd}	[kN]	12,0	17,0	24,9	37,7	--	--
A4-50	Tensile	N_{Rd}	[kN]	5,0	7,1	10,4	15,7	--	--
	Shear	V_{Rd}	[kN]	3,8	6,3	8,8	16,4	--	--
A4-70	Tensile	N_{Rd}	[kN]	5,0	7,1	10,4	15,7	--	--
	Shear	V_{Rd}	[kN]	8,3	12,8	19,2	35,3	--	--

Combined tension and shear loading in accordance with EN 1992-4:2018 and AS 5216:2018 please refer to ICCONS Designfix software or contact Iccons engineering department engineering@iccons.com.au for further information.



Static and quasi-static resistance (for a single anchor)

All data in this section subject to:

- Correct setting (see setting instructions).
- No edge distance and spacing influence.
- Standard embedment depth ($h_{ef,calc}$), as specified in the 'Installation Dimensions' table.
- Concrete C20/25, $f_{ck} = 20 \text{ N/mm}^2$.
- Temperature range I: (max. long/short term temperature $+24^\circ\text{C}/+40^\circ\text{C}$).
- Shear loads are calculated without the influence of a lever arm.
- $\psi_{SUS} = 1,0$ according EN 1992-4:2018; eq. 7.14a.
- Recommended loads are with overall partial safety factor for action $\gamma_G = 1,4$. The partial safety factors for action depend on the type of loading and shall be taken from national regulations.



Recommended Loads Dry/Wet Concrete & Flooded Holes

Non-Cracked Concrete		D _a		m8	m10	m12	m16	m20	m24
Steel 5.8	Tensile	N _{rec}	[kN]	6,8	9,0	13,2	19,9	33,9	50,3
	Shear	V _{rec}	[kN]	6,3	9,7	14,3	26,9	42,3	60,6
Steel 8.8	Tensile	N _{rec}	[kN]	6,8	9,0	13,2	19,9	33,9	50,3
	Shear	V _{rec}	[kN]	8,6	13,1	19,4	36,0	56,0	80,6
A4-50	Tensile	N _{rec}	[kN]	4,5	7,2	10,5	19,7	30,7	44,2
	Shear	V _{rec}	[kN]	2,7	4,5	6,3	11,7	18,3	26,4
A4-70	Tensile	N _{rec}	[kN]	6,8	9,0	13,2	19,9	33,9	50,3
	Shear	V _{rec}	[kN]	6,0	9,2	13,7	25,2	39,4	56,8

Cracked Concrete		D _a		m8	m10	m12	m16	m20	m24
Steel 5.8	Tensile	N _{rec}	[kN]	3,6	5,0	7,4	11,2	--	--
	Shear	V _{rec}	[kN]	6,3	9,7	14,3	26,9	--	--
Steel 8.8	Tensile	N _{rec}	[kN]	3,6	5,0	7,4	11,2	--	--
	Shear	V _{rec}	[kN]	8,6	12,1	17,8	26,9	--	--
A4-50	Tensile	N _{rec}	[kN]	3,6	5,0	7,4	11,2	--	--
	Shear	V _{rec}	[kN]	2,7	4,5	6,3	11,7	--	--
A4-70	Tensile	N _{rec}	[kN]	3,6	5,0	7,4	11,2	--	--
	Shear	V _{rec}	[kN]	6,0	9,2	13,7	25,2	--	--

Combined tension and shear loading in accordance with EN 1992-4:2018 and AS 5216:2018 please refer to ICCONS Designfix software or contact Iccons engineering department engineering@iccons.com.au for further information.

Seismic resistance (for a single anchor)

All data in this section subject to:

- Correct setting (see setting instructions).
- No edge distance and spacing influence.
- Standard embedment depth ($h_{ef,calc}$), as specified in the 'Installation Dimensions' table.
- Concrete C20/25, $f_{ck} = 20 \text{ N/mm}^2$.
- Temperature range I: (max. long/short term temperature +24°C/+40°C).
- Shear loads are calculated without the influence of a lever arm.
- $a_{gap} = 1,0$ (using special filling washer, according t.b.d. Annex A3).



Steel Decisive

Desing Resistance Dry/Wet Concrete & Flooded Holes in Case of Seismic Performance Category C1

Cracked Concrete		D_a		m8	m10	m12	m16	m20	m24
Steel 5.8	Tensile	$N_{Rd,eq,C1}$	[kN]	2,6	3,5	5,3	7,7	--	--
	Shear	$V_{Rd,eq,C1}$	[kN]	5,2	7,2	10,8	15,7	--	--
Steel 8.8	Tensile	$N_{Rd,eq,C1}$	[kN]	2,6	3,5	5,3	7,7	--	--
	Shear	$V_{Rd,eq,C1}$	[kN]	5,2	7,2	10,8	15,7	--	--
A4-50	Tensile	$N_{Rd,eq,C1}$	[kN]	2,6	3,5	5,3	7,7	--	--
	Shear	$V_{Rd,eq,C1}$	[kN]	2,6	4,4	6,2	11,5	--	--
A4-70	Tensile	$N_{Rd,eq,C1}$	[kN]	2,6	3,5	5,3	7,7	--	--
	Shear	$V_{Rd,eq,C1}$	[kN]	5,2	7,2	10,8	15,7	--	--



Desing Resistance Dry/Wet Concrete & Flooded Holes in Case of Seismic Performance Category C2

Cracked Concrete		D_a		m8	m10	m12	m16	m20	m24
Steel 8.8	Tensile	$N_{Rd,eq,C2}$	[kN]	--	--	1,7	3,3	--	--
	Shear	$V_{Rd,eq,C2}$	[kN]	--	--	3,5	6,8	--	--
A4-70	Tensile	$N_{Rd,eq,C2}$	[kN]	--	--	1,7	3,3	--	--
	Shear	$V_{Rd,eq,C2}$	[kN]	--	--	3,5	6,8	--	--

Combined tension and shear loading in accordance with EN 1992-4:2018 and AS 5216:2018
please refer to ICCONS Designfix software or contact Iccons engineering department
engineering@iccons.com.au for further information.



REINFORCING BARS



Rebar:

EN 1992-1-1:2004+AC:2010, Annex C

Bars are de-coiled rods class B or C

f_{yk} and k according to NDP or NCL of EN 1992-1-1/NA

$f_{uk} = f_{tk} = k \cdot f_{yk}$

Installation Procedures

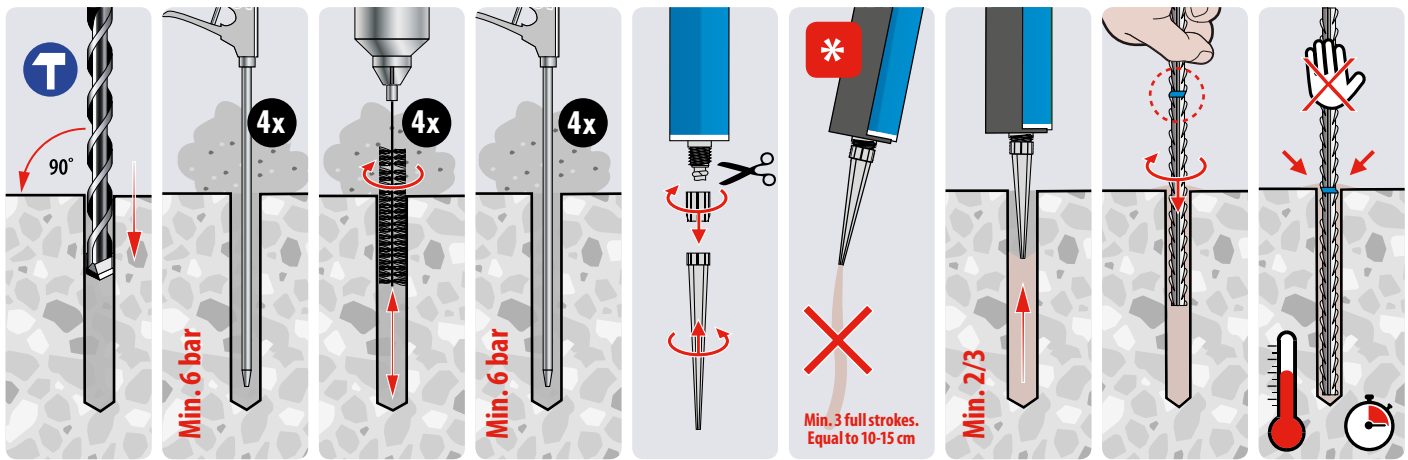

Curing Times¹⁾

Temperature ²⁾	-5°C to -1°C	+0°C to +4°C	+5°C to +9°C	+10°C to 14°C	+15°C to +19°C	+20°C to +29°C	+30°C to +34°C	+35°C to +39°C
Working Time	90 min	45 min	25 min	20 min	15 min	6 min	4 min	2 min
Curing Time	6 h	3 h	2 h	100 min	80 min	45 min	25 min	20 min

1) Cartridge Temperature must be between +5°C and +40°C. 2) Concrete Temperature



Specification Data for the use in Cracked and Non-Cracked Concrete and Hammer/Air Drilled Holes according to EAD 330499-01-0601 and AS 5216:2018

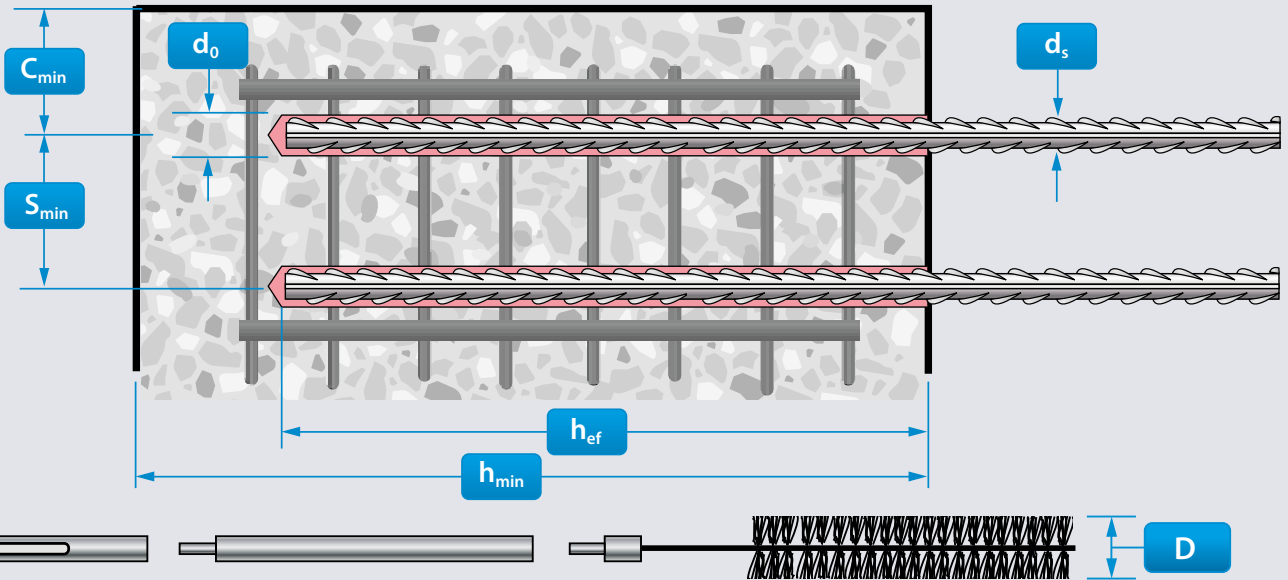

Installation Dimensions

Rebar Size	d_{nom}		Ø8	Ø10	Ø12	Ø14	Ø16	Ø20	Ø25
Min. Eff. Anchorage Depth	$h_{ef,min}$	[mm]	60	60	70	75	80	90	100
Max. Eff. Anchorage Depth	$h_{ef,max}$	[mm]	160	200	240	280	320	400	500
Hole Diameter	d_o	[mm]	12	14	16	18	20	25	32
Required Volume per cm Embedment Depth	V_s	[ml/cm]	0,75	0,90	1,06	1,21	1,36	2,12	3,76

Member Thickness, Edge Distance & Spacing

Rebar Size	d_{nom}		Ø8	Ø10	Ø12	Ø14	Ø16	Ø20	Ø25
Min. Member Thickness	h_{min}	[mm]	$h_{ef} + 30 \text{ mm}$ $\geq 100 \text{ mm}$			$h_{ef} + 2d_o$			
Min. Edge Distance	C_{min}	[mm]	50	55	65	70	80	100	130
Min. Spacing	S_{min}	[mm]	50	55	65	70	80	100	130

Steel Brush & Piston Plug Dimensions

Rebar Size	d_{nom}		Ø8	Ø10	Ø12	Ø14	Ø16	Ø20	Ø25
Brush Diameter	D	[mm]	13,5	15,5	17,5	20,0	22,0	27,0	34,0
Min. Brush Diameter	D_{min}	[mm]	12,5	14,5	16,5	18,5	20,5	25,5	32,5
Piston Plug	#	--	No piston plug required			18	20	25	32



Static and quasi-static resistance (for a single anchor)

All data in this section subject to:

- Correct setting (see setting instructions).
- No edge distance and spacing influence.
- Minimum and maximum embedment depth, as specified in the 'Installation Dimensions' table.
- Concrete C20/25, $f_{ck} = 20 \text{ N/mm}^2$.
- Temperature range I: (max. long/short term temperature $+24^\circ\text{C}/+40^\circ\text{C}$).
- Shear loads are calculated without the influence of a lever arm.
- $\psi_{sus} = 1,0$ according EN 1992-4:2018; eq. 7.14a.
- Recommended loads are with overall partial safety factor for action $\gamma_G = 1,4$. The partial safety factors for action depend on the type of loading and shall be taken from national regulations.



Design Resistance Dry/Wet Concrete and Flooded Holes

Non-Cracked Concrete		d_{nom}		Ø8	Ø10	Ø12	Ø14	Ø16	Ø20	Ø25
B500B	Tensile Min.	$N_{Rd,min}$	[kN]	5,9	7,3	10,3	12,8	14,5	20,4	27,3
	Tensile Max.	$N_{Rd,max}$	[kN]	15,6	24,4	35,2	47,9	58,1	90,8	141,8
	Shear Min.	$V_{Rd,min}$	[kN]	9,2	14,5	20,7	28,2	34,9	49,0	65,6
	Shear Max.	$V_{Rd,max}$	[kN]	9,2	14,5	20,7	28,2	36,9	57,6	90,0



Recommended Loads Dry/Wet Concrete and Flooded Holes

Non-Cracked Concrete		d_{nom}		Ø8	Ø10	Ø12	Ø14	Ø16	Ø20	Ø25
B500B	Tensile Min.	$N_{rec,min}$	[kN]	4,2	5,2	7,3	9,2	10,4	14,6	19,5
	Tensile Max.	$N_{rec,max}$	[kN]	11,2	17,5	25,1	34,2	41,5	64,8	101,3
	Shear Min.	$V_{rec,min}$	[kN]	6,5	10,3	14,8	20,2	24,9	35,0	46,9
	Shear Max.	$V_{rec,max}$	[kN]	6,5	10,3	14,8	20,2	26,3	41,1	64,3

Combined tension and shear loading in accordance with EN 1992-4:2018 and AS 5216:2018 please refer to ICCONS Designfix software or contact Iccons engineering department engineering@iccons.com.au for further information.



BIS-P GEN2 Mortar Properties

B+BTec BIS-P GEN2 injection mortar may be applied in cracked and non-cracked concrete, lightweight-concrete, aerated-concrete and natural stone (Attention! natural stone can discolour, this shall be checked in advance.). In the table below the physical properties of the B+BTec BIS-PE GEN3 are listed.

Properties	Test Method	Result
UV Resistance		Pass
Watertightness	DIN EN 12390-88	0 mm
Temperature stability		≤ 120 °C
Desity		1.77 kg/dm ³
Compressive strength	DIN EN 196-1	100 N/mm ²
Flexural strength	DIN EN 196-1	15 N/mm ²
E modulus	DIN EN ISO 527-2	14000 N/mm ²
Shrinkage		≤ 0.3%
Hardness shore D		90
Electrical resistance	IEC 93	3,6 109 W m
Thermal conductivity	IEC 60093	0.65 W/m•K

BIS-P GEN2 Chemical Resistance

The resistance of the B+BTec BIS-P GEN2 injection mortar to chemical substances is given in the table below. The data in this table are applicable to brief periods of chemical contact with full cured adhesive (e.g. temporary contact with adhesive during a spill).



Chemical Agent	Concentration	Resistant	Not resistant
Acetone	10		■
Beer		■	
Diesel Oil		■	
Ethanol	50		■
Fuel Oil		■	
Gasoline (premium grade)		■	
Hydraulic Fluid		■	
Hydrogen Peroxide	10		■
Sea water, salty		■	

NOTES:

Large empty rectangular area for notes.



Anchoring

PURE EPOXY GEN³

Adhesive

ICCONS[®]



DESIGN FiX[®]

anchor design made easy

- An innovative 3D visual user interface, utilizing EN 1992-4 design methodology and suitable for design in accordance with AS 5216:2018
 - Seismic design under earthquake loads according to EN 1992-4, TR 045, TR 049
 - Finite element analysis steel baseplate design
- ICCONS DesignFiX[®] is a simple, intuitive and free to download (registration required) anchor design program for design engineers, project managers, site engineers and end users. Complex mechanical or chemical heavy duty anchor arrangements can be calculated in minutes.

INCLUDES THE NEW BIS PE GEN3 PURE EPOXY WITH 100 year design service life assessed in accordance with EAD 330499-01-0601

Optimum BIS Injection System anchorage depth

When selecting a BIS Adhesive Injection System, ICCONS DesignFiX allows for the automatic calculation of the most effective anchorage depth, taking into consideration the minimal and maximum values of the ETA.

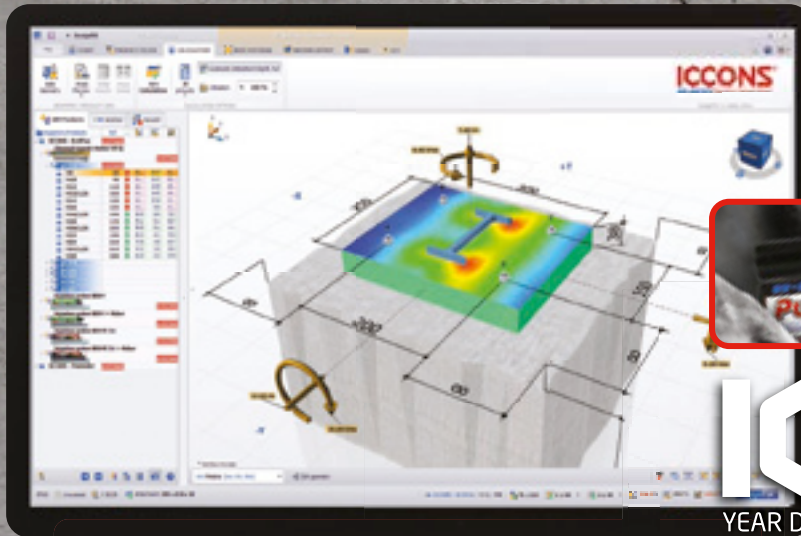

100+

YEAR DESIGN LIFE

FREE DOWNLOAD www.iccons.com.au/software/anchor-design-software

Input freedom & 3D user interface

ICCONS DesignFiX offers complete freedom to select an anchor pattern and base plate configuration, as well as the position and direction of load combinations. Changes are made directly into the 3D user interface.

Anchor type comparison

ICCONS DesignFiX displays the usability of the various anchor types (according to EN 1992-4) including the values for each load type. This allows you to compare the calculation results of the different anchor types in a single easy to read panel. Design results suitable for use in accordance with AS 5216:2018.

Calculate base plate thickness

The integrated FEM-Calculation Method (Finite Element Method) in ICCONS DesignFiX allows you to calculate the base plate thickness based upon the stresses in the base plate in combination with the base plate configuration.

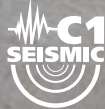

For further details contact engineering@iccons.com.au | www.iccons.com.au



VICTORIA - HEAD OFFICE

383 Frankston-Dandenong Road Dandenong South
Victoria 3175
P: 03 9706 4344
F: 03 9768 3329
E: sales@iccons.com.au

NSW Branch

Unit A, 17 Seddon Street, Bankstown,
New South Wales, 2200
P: 02 9791 6869
F: 02 9790 8404
E: salesnsw@iccons.com.au

QLD Branch

42-44 Nealdon Drive, Meadowbrook,
Queensland, 4131
P: 07 3200 6455
F: 07 3299 7548
E: salesqld@iccons.com.au

S.A Branch

29-31 Weaver Street, Edwardstown,
South Australia, 5039
P: 08 8234 5535
F: 08 8354 4689
E: salessa@iccons.com.au

W.A. Branch

90 Christable Way, Landsdale,
Western Australia, 6065
P: 08 6305 0008
F: 08 6305 0011
E: saleswa@iccons.com.au

NORTHERN TERRITORY

Unit 1, 14 Menmuir Street, Winnellie,
Northern Territory 0820
P: 08 8947 2758
F: 08 8947 2758
E: salesnt@iccons.com.au

NEW ZEALAND

Sesto Fasteners
5E Piermark Drive, Rosedale, Auckland,
New Zealand 0630
P: +64 027 526 6403
E: sestofasteners@gmail.com

ICCONS (Thailand) Co. Ltd.

55 Phetkasem 62/3, Bangkhae,
Bangkok 0160
P: + 66 2 801 0764
F: + 66 2 801 0764
M: + 66 8 1 710 8745
E: icconsthailand@hotmail.com