

Checklist of Preventive Products for Home Security

- Folding Rule
- Rubber Cement
- Door Locks
- Step Ladder
- Spot Lights
- Outlet Box
- Power Drill
- Plug-in Timer
- Screwdriver
- Hand Drill
- Steel Rod
- Junction Box
- Burglar Alarms
- Automatic Timer
- Door Viewer
- Socket Bolts
- Chain Door Guards
- Patio Security Bolts
- Concealed Security Chain
- Pad Bolts
- Hasp and Staples
- Padlocks
- Sensor Light

What is security?

Security is a broad concept involving not only locks but other protective devices, such as intrusion alarms and reporting systems, proper indoor and outdoor lighting, marking of valuables for identification, and equally important, concerned and observant neighbours helping to protect each other's property.

The selection of a lock should be based on the degree of security required and should be in keeping with precautions taken to protect windows, garage and patio doors, even vent openings that are large enough for access.

Some General Safety Precautions

There is no unbeatable way to protect a home from break-ins. Locks and other safety devices serve primarily to prevent entry by the amateur and to slow or deter the professional.

Try to avoid regular routines which make it obvious that you are away from home at specific times of the day or night. Sometimes this is unavoidable, but vary the routines of departure and arrival as much as possible.

Never chat idly with strangers about leaving your home for a vacation or a visit etc. You never know who may be watching for an opportunity to break in.

Alert your local police. Stop the delivery of papers and milk etc to reduce tell tale signs when you will be away from home for extended periods of time.

Arrange for someone to mow your lawns if it is necessary for the family to be away. This gives an appearance that someone is at home. Such

precautions could be well worth the cost of the lawnmowing.

Work out an arrangement with a reliable neighbour for mutual alertness when anyone in the neighbourhood has to be away.

Use any other precautions to make it appear that someone is at home at all times as much as possible.

Installing Lights For Protection

Good lighting is one of the greatest deterrents to crime. Floodlights mounted on the corner of a house (Fig. 1) can light up the walls of the house in both directions.

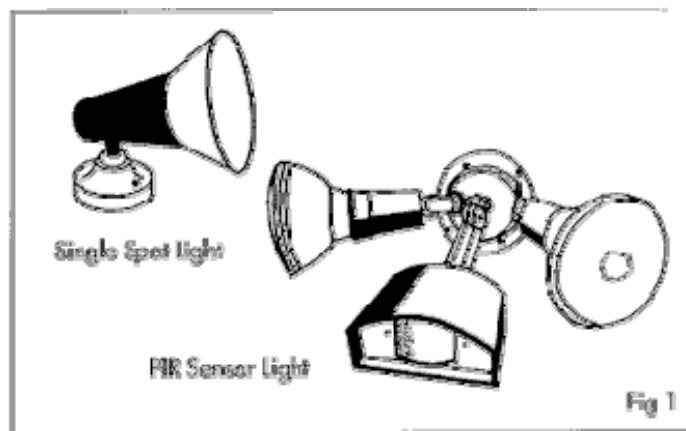

Such lights are inexpensive, relatively easy to mount and are highly effective in reducing break-ins.

Spotlights (Fig. 1), can be either single or double. The double spotlight is recommended. Always mount the light high enough that it cannot be unscrewed easily by a burglar who is standing on the ground.

Flood lights mounted high on the end of the house (Fig. 2) provide a great amount of light for a wide area. Lights of this type can be either single or double, although double is strongly recommended.

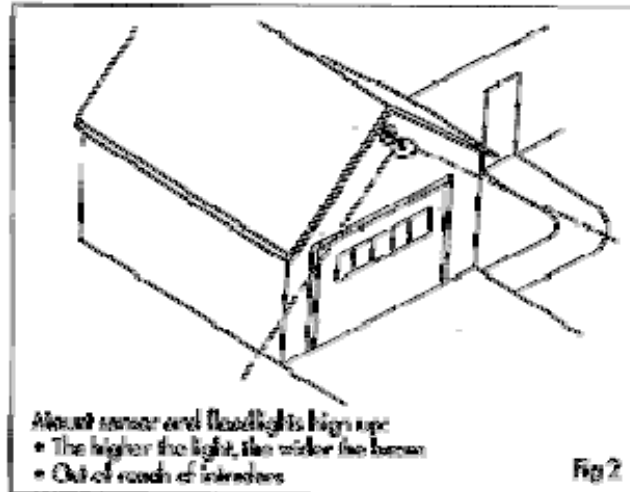

Lights mounted on either the corner or end of the house should be set in such a way that they illuminate dark areas behind rose bushes, screens, walls, trees, etc.

Mount lights of the type shown in Fig. 1 in spots around the house that might provide a hiding place for burglars or peeping toms.

Before fitting any electrical lighting apparatus seek the assistance of a qualified electrician.

Passive infrared (PIR) or sensor lights instantly light when the PIR field of view is interrupted by an unwelcome visitor. By sensing heat and movement they not only deter intruders, but also act as a welcome light in the evening.

Plug-in timers (Fig. 3) can be used to turn the spotlights on or off when you are away. Timers of the type illustrated can be used for activating and turning off the lights in any or all rooms of the house.

When timers of this type are used, do not set them so all are turned on or off at one time. For example, the light in one room might be set to come on for a short interval at about two o'clock in the morning while another light in another room might be set to kick on and off at a totally different time. Such variations in timing provide a more natural lighting use to any outside observer.

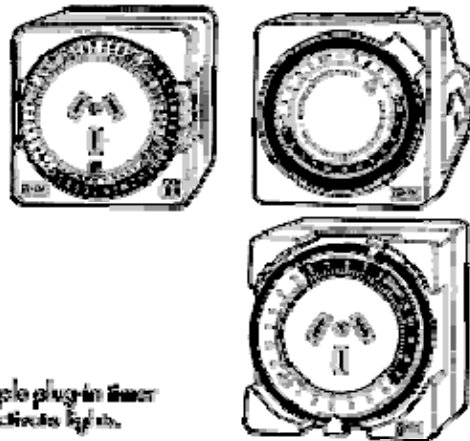

A simple plug-in timer can activate lights.

Automatic timers can be installed in the main power line to spotlights mounted around the house. Timers of this type enable you to activate the lights every night, every other night or at any frequency or interval desired. Have a qualified electrician wire these into your system.

Do not overlook the security value of good lighting. It is one of the cheapest yet most effective ways to reduce break-ins.

Warning: Replace burned out bulbs immediately! The whole lighting system becomes ineffective if burned out bulbs are not quickly removed and replaced.

Simple Non-Electric Security Devices

Securistay

The Securistay fits to projected, top hung fan- lights and sashes, or side hung casements where you want open windows for ventilation but you also want reasonable security.

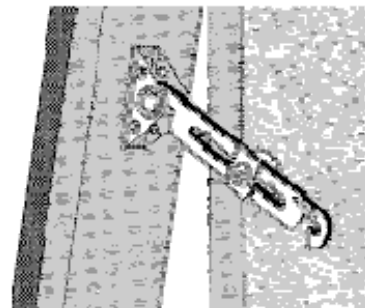

The Securistay can be disengaged for full window opening and cleaning only when the window is tightly closed. It then re-engages automatically again when closed. For increased security, the Securistay can be locked with a key supplied, preventing anyone either side from opening the window more than 100mm. Securistays are recommended where you want to control large sashes in high wind conditions.

The Securistay holds the window positively in three positions for ventilation with increased security. However, while it will hinder unlawful entry, it won't prevent it. Keep windows closed and locked when the house is empty.

Securistays comply with NZS4211 Window Performance Standards, and have an electrostatic epoxy powder finish.

Double Hung Sash Security

Bore a 6mm hole through the top rail of the bottom sash and into the bottom rail of the top one. A cut down 100mm nail pushed into the hole so that just the head shows prevents either sash from moving (See Fig 4). Proprietary locks using this principle are also available.

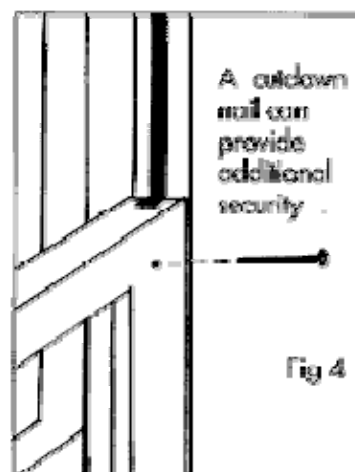

Door Viewer

One way viewers (Fig. 5) are easy to install. It is simply a matter of drilling a hole to the proper size, inserting the viewer and tightening it up.

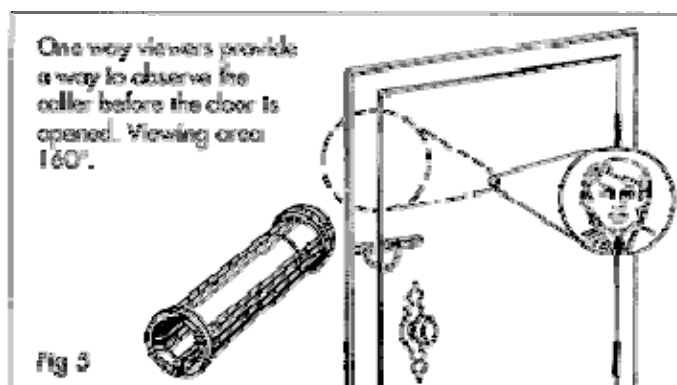

Door Guard

High security, easily installed, simple to operate, manufactured in machine cast steel, this door guard allows the door to be partly opened yet remain secure in the held position.

Ideal for residential and commercial applications, available in bronze and brass finishes, comes complete with all necessary fixing instructions and fastenings. Any door guard will only be effective if very securely anchored. Long, stout screws into a solid door frame are essential.

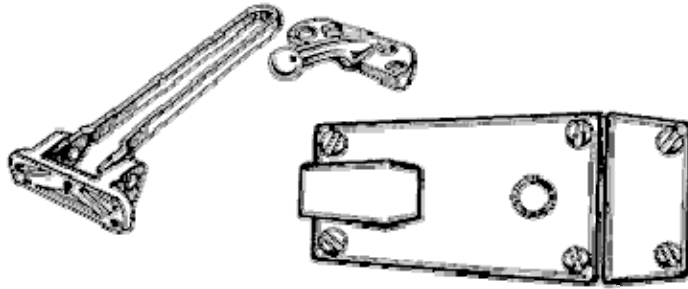

Night Latch

The traditional front door latch is the most economical option. However it doesn't offer the security you need today. It is surface mounted with screws only into light timber, so the door is easily burst in.

A rim plate is available for inwards or outwards opening doors.

Brass cylinder, hold back snib, and brass bolt can be master keyed or keyed alike to other locks. In chrome, bronze or satin finishes.

Cabinet Deadlock

Can be surface mounted. It is ideal for poison cupboard applications. The solid brass bolt can be applied to any "hand" or door and can be keyed with other pin tumbler locks. A trim collar escutcheon allows a neat appearance by covering the bore edge. Maximum door thickness 28mm. Throw of bolt when locked 25.4mm.

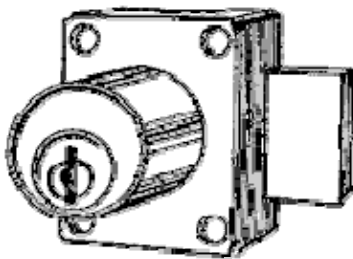

Double Cylinder Deadbolts

Can be installed as either a primary or auxiliary lock. Operated by key either side. Has a strong 25mm throw deadbolt as recommended by crime prevention experts worldwide.

Construction includes reinforced tapered cylinder ring that resists wrenching. Available in chrome, bronze and polished brass finishes. This high quality lock can be keyed to other cylindrical locks. Also available as single cylinder operating unit as illustrated with lever action turn units inside for easy locking, unlocking and emergency exit.

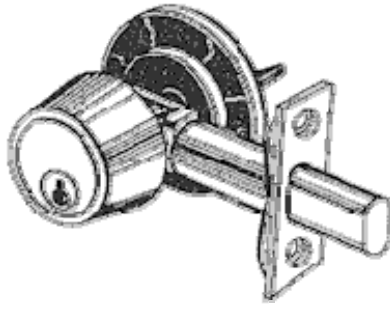

Improved Security Through Better Locks

The typical lock in the modern home offers very little protection against break-ins.

Tubular and cylinder deadlocks provide a great deal of extra protection when used as a supplement to the regular locks in the home. The tubular deadlock provides a great deal of protection without unsightly appearance. The double tubular deadlock can be installed in any door.

Examine the locks in your home carefully. If they are old, worn or fail to give the needed protection, install new or supplementary locks immediately.

How Much Should A Lock Cost?

The cost of a lock generally reflects the quality of workmanship and materials used. When replacing a door and buying a new lock, you should expect to pay as much or more for the lock as you pay for the door.

A word of warning: The "cheapest lock" can prove to be very costly; materials used in its manufacture can be of inferior quality and have a short life, thereby requiring early replacement or repairs (life cycle value).

Cost should be considered on a long term basis, for quality locks (both interior and exterior), when properly installed and maintained should last the life of the house. You should rarely have to replace a good lock.

Where Do You Use a Lock?

For doors in a residence, there are three basic types of locking operations:

1. Keyed Lock

For front doors, back doors, storage rooms.

Entrance Lock -front and back doors, panic free exit.

Utility Lock -low security economy lock.



2. Simple Latches, or "Passage Latch"

For closets, hallway doors, some bedrooms. Dummy trim -wardrobe cupboard door pull handles.

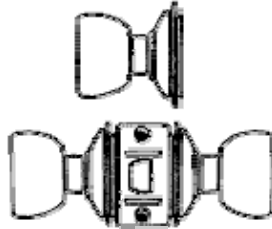

3. Keyless locks

Privacy Lock for bathrooms, bedrooms, toilets.

Patio Lock -for exterior doors not requiring key operation.

Finish Selection

Good lock finishes are durable, top-quality finishes obtained by careful processing of solid brass, bronze or stainless steel from which all exposed parts are made. Where required, a high-quality clear protective coating is electrostatically applied and cured in a high temperature infra-red oven.

It is important that climatic conditions and usage be taken into consideration when selecting finishes. This is especially so in areas subjected to strong corrosive vapours, humid climate, sea air or salt spray, which, in a short time will affect metal finishes. Even the clear coating, which is applied under carefully controlled conditions and provides the best possible protection, cannot guarantee the original appearance over an extended period of time.

Triple Action Dual Locks

1. Deadbolt Security:

One of the most often recommended burglary deterrents.

2. Life Safety Feature:

Allows fast, easy emergency exit by turning the inside knob.

3. Latchbolt Convenience:

Door is controlled by latch bolt when dead bolt is not in use.

All this in one lock and one easy installation.

A deadlocking latch is either locked, needing a key from each side; or unlocked, in which case you use the (latch) handle.

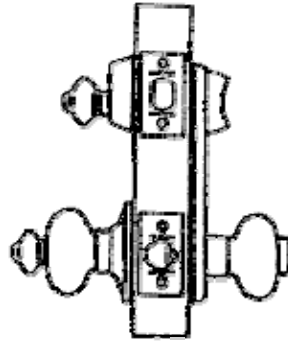

An alternative is to team up a deadbolt and locking latch.

- When you are out, lock the deadbolt and the latch.
- When in bed, just lock the latch.
- The inside handle locks with a push-in knob rather than a key, and can always be opened from the inside.

Patio Keyed Security Bolt

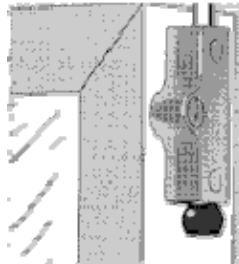

For aluminium or timber siding doors. Also hinged doors, bi-fold doors, large windows, security screen doors, etc. All fitting instructions provided. Can be keyed alike if required.

Concealed Security Chain

This product is of superior quality and appearance to the standard door chain. Strong and durable to withstand repeated aggressive impact. The high tensile steel one way chain retracts automatically inside the door. The switch can only be turned to the off position when door is completely closed.

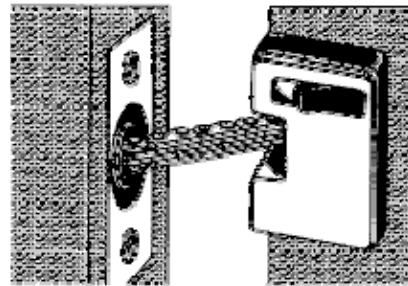

Easy installation can be achieved with a drill, chisel and screwdriver.

Security Chain Door Guards

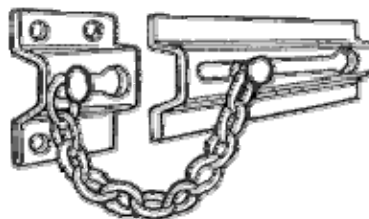

These can be fitted to the inside of any exterior door opening. Very easy to install by using a drill and screwdriver. They offer initial and limited personal security.

Socket Bolts

For minor security, these can be fitted to the interior side of any door, opening either in or out. They are available in many sizes and finishes, all extruded from brass castings.

Two types make up the range. Namely the straight bolt and the necked bolt extension. The straight bolt fits into a cast barrel socket whereas the necked bolt fits into a flat plate. Tools required are a drill and a screwdriver. They are very easy to install.

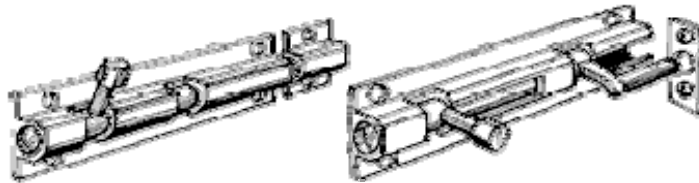

Pad Bolts

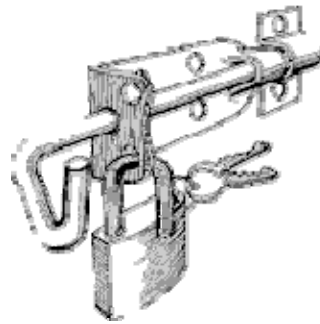

These are in the main used on outside buildings such as garages, sheds and on many construction sites. Pad bolts are of galvanised finish for durability. They are available in three sizes, 100mm, 150mm and 200mm. Best bolted onto the door and frame as screws can be simply unscrewed. Tools required -a drill and an adjustable spanner.

Hasp & Staples

These also are in the main used on outside buildings such as garages, sheds and construction sites. Manufactured with a galvanised coated finish. Available in 75mm - 110mm - 150mm -200mm. When installed all the screw fixings are concealed. Tools required -a drill and screwdriver.

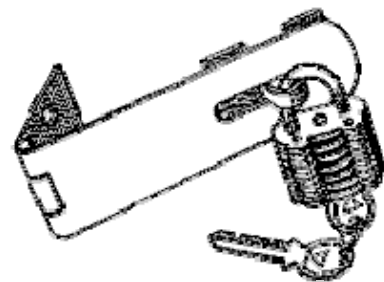

Padlocks



Padlocks vary in many ways, namely:

- 1 .Size of shackles
 2. Hardened or solid brass shackle
 - 3.Construction -brass or laminated
 4. Light to heavy duty
 5. Keying can be supplied. If keyed alike many people are able to operate the one padlock. The number of different key changes vary on good quality padlocks from 900 to 3000.
-

Some Facts

- Burglary is on the increase and a quality dead bolt is an excellent deterrent.
 - It stops unwelcome guests getting in and from getting out with your goods.
 - Screw-on devices are only as good as their fixing to the door or wall.
 - Security shouldn't prevent your easy exit from the house.
 - Keys should be left in locks at night or use a lock that allows a rapid exit in case of emergency.
-

Produced by PlaceMakers in association with the Building Research Association of New Zealand.

To locate the nearest PlaceMakers store, [click here](#)

Please Note:

Whilst the advice and recommendations contained in this brochure have been produced with proper care, they are offered only with the object of assisting those interested in home improvement projects and PlaceMakers does not accept responsibility for the advice, recommendations, etc, contained herein.
<http://www.placemakers.co.nz/find-us/findus.asp>
