

HOW TO

6

Know how. Can do.

Working with concrete.

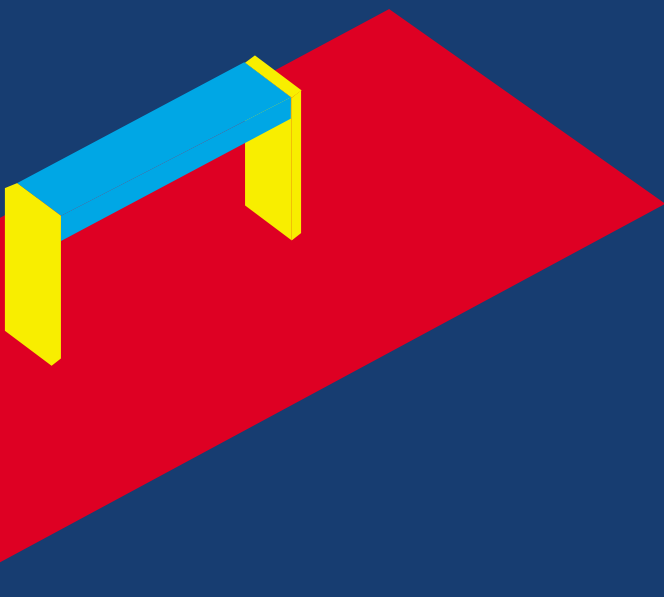

PlaceMakers

www.placemakers.co.nz

Tools and Material Checklist

- Concrete Mix
- Garden hose
- Wooden float
- Steel float
- Hammer
- Spade
- Groover
- Length of 50x50 timber for a screed
- Stringline
- Brush or broom
- Bucket
- Timber for boxing, pegs and braces
- Nails
- Rubber boots
- Line level
- Reinforcing mesh and possibly steel
- Shovel
- Wheelbarrow

Here are tips and instructions on how to work with concrete. Take time to read them thoroughly. Following these can save time and effort. It can also help you achieve a neater, more satisfactory installation, with less waste.

Decide how to obtain your concrete

Concrete comes in many forms. Bagged, dry pre-mix which requires only the addition of water is the simplest to use. It is ideal for small jobs but is expensive for large projects. Ready-mix concrete is delivered in concrete mixer trucks. This is the simplest and easiest way to buy concrete for large projects. However you obviously have to pay for the delivery and convenience of ready-mix concrete. PlaceMakers can arrange the supply of ready-mix. You can of course buy the dry ingredients and mix them yourself. Whether that proves to be cheaper or not will depend on prices in your area. It also involves hiring or purchasing of the necessary mixers, and cartage. There is also more risk that you won't achieve the optimum mix for your job.

Mixing your own concrete

There are four basic elements involved in mixing concrete:

1. cement,
2. fine aggregate such as sand,
3. coarse aggregate such as crushed rock or gravel,
4. water for mixing the ingredients to type of paste or sloppy mix.

The aggregates can be bought ready graded as 'builders mix'. All aggregates used should be free of organic matter.

Water for making concrete should be clean, free of acids, alkalis, oils and sulphates.

The ingredients in concrete are always the same, but results depend largely on the proper mix of the four elements. The intended use of the concrete will determine their proportions.

If you are pouring heavy footings for walls where waterproofing is not a requirement, your mix can be 1 part cement to 6 parts builders mix.

For paths, steps and driveways use 1 part cement to 5 parts builders mix.

You can measure the ingredients on small jobs with a bucket.

Always follow the instructions on the cement bag when mixing concrete.

Add water to the ingredients to achieve a pliable or plastic mix of concrete.

Concrete admixtures are available at PlaceMakers to help make the concrete easier to work with.

A very sloppy mix will result in weak concrete and a poor surface which is likely to be dusty when cured.

Calculate the Volume of concrete required

1. Multiply the length by the width. This gives the area in square metres. (eg: Your drive is 24 metres long and 2.4 metres wide and you need it 75mm (0.075m) thick).

$$\text{(eg. } 24 \times 2.4 = 57.6 \text{ M}^2\text{)}.$$

2. Multiply the square metres by the thickness in metres. (eg. $57.6 \times 0.075 = 4.32 \text{ M}^3$).

This gives the volume of concrete required, in cubic metres.

Fig 1

Building the boxing for concrete

Almost any job involving concrete requires some type of 'boxing' which holds the freshly poured concrete in place and stops it spreading and slumping into areas where it is not needed. Sometimes the boxing is above the ground. At other times, some digging is needed. Special boxing grade timber is available from all PlaceMakers Stores.

- Dig down to the desired level and build the boxing to the necessary shape and size.
- Establish a reference height at the highest point.
- Paths against a house must be kept 150mm below concrete floor level and slope slightly away, so water does not drain under the house.
- Gardens against the house must be kept 225mm below concrete floor level.

So for a path against a house:

- Start at the house.
- Set the desired height at the reference end.
- Use a level to establish the slope and then run the boxing planks to the other end.
- For a long path, you can use a stringline and line level to establish an even slope.
- Peg and fix the boxing planks at both ends.
- Then drive pegs between the ends and nail the boxing to them.
- Keep the boxing planks straight and sloping evenly as you go.

Pouring concrete

After the boxing is fixed, lightly spray the entire area within the boxing with water from a garden hose, then pour in the concrete. After the boxing is filled:

- 'Tamp' the freshly poured concrete to compact it. This can be done either by tamping with the end of a sturdy piece of timber, or by walking around on the poured concrete wearing rubber boots.
- Pay particular attention to the edges.
- After tamping, use a 150 x 50mm length of timber as a screed.
- Work the screed back and forth in a saw like fashion to level the concrete surface at all points.

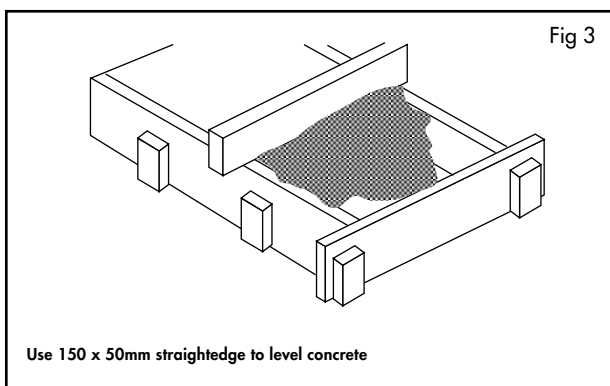
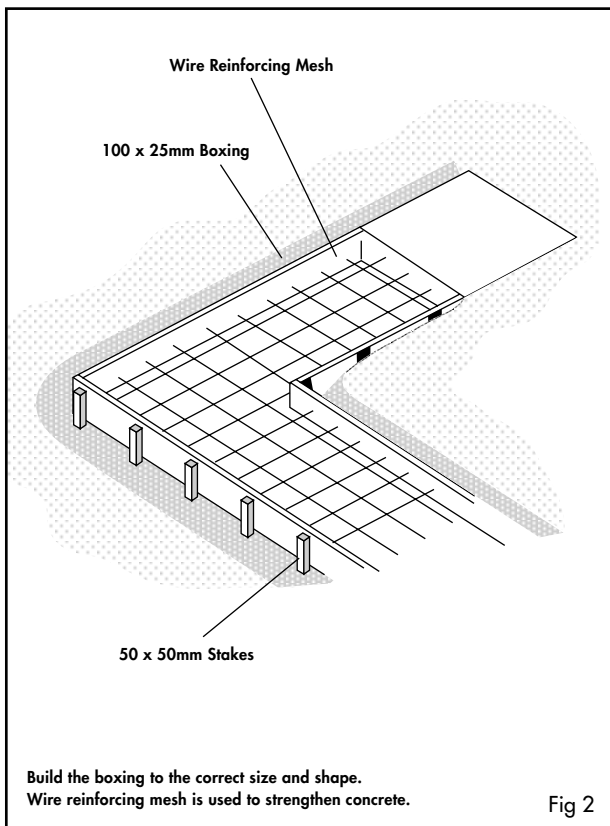

Crack control joints

Concrete shrinks and cracks as it hardens. Grooving the concrete to form crack control joints will encourage it to crack in neat straight lines. Crack control joints should be a third of the thickness of the concrete deep. In a footpath they should be across the width every 2 metres.

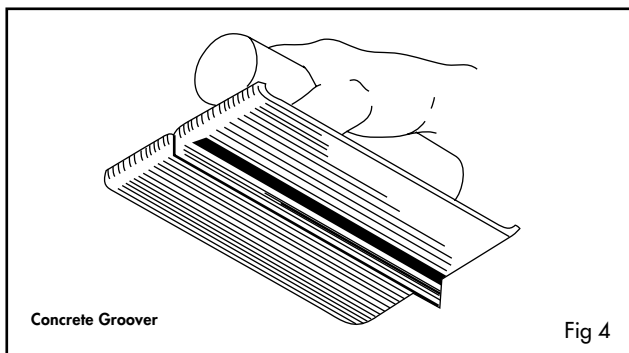

For a larger slab up to 100mm thick, they should be at 3 metre intervals in both directions for unreinforced concrete, and at 5 metres in reinforced concrete.

To groove in a straight line:

- Wait until the concrete is dry enough to support a 200x50 plank.
- Lay the plank across the concrete and run the groover across, using the plank as a guide.

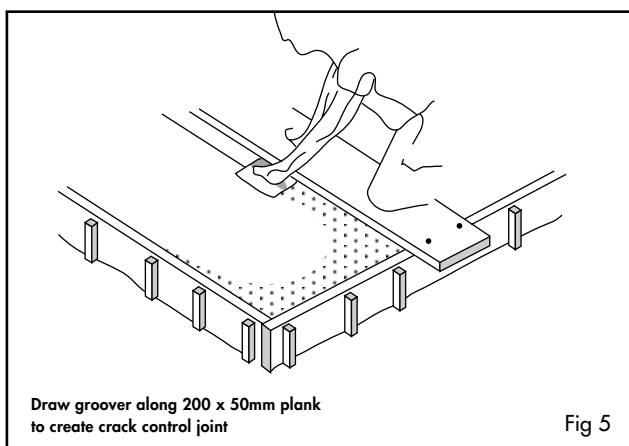

Reinforcing

Reinforcing is not mandatory in driveways, paths or non-loadbearing slabs in single storey houses. However it will help to control cracking and to hold a slab together if there is uneven settlement of the subgrade. To do that reinforcing must be positioned in the top half of the thickness of the concrete slab.

Reinforcing steel sizes mainly used are No's 665 and 668. Both have 150x150 squares. 665 is made from 5.3mm diameter steel. 668 is made from 4mm steel. Both are available in various sized sheets.

Expansion joints

Concrete expands and contracts with temperature variations. To allow for this movement, expansion joints must be provided at 18 metre intervals. These must be the full depth of the slab and must be filled only with flexible material, not timber.

- To create an expansion joint, paint a thin plank with motor or form oil.
- Set the plank on edge into the concrete, so that it spans the full depth of the concrete.
- To allow screeding, it's top edge should be at the same level as the surface.
- When the concrete has partly hardened, screw a strong screw into the edge of the plank and pulling on that, gently remove the plank.
- The resulting gap can be filled with flexible material when the concrete is completely hard.

Different ways to finish concrete

No final finishing should be done before all free surface moisture has evaporated. Concrete can be given a smooth finish with a wooden, and then a steel float. If a completely smooth finish is not wanted, use only the wooden float.

A light swirled pattern can be created by holding a steel float flat on the surface and moving it in a swirling motion during the last floating off.

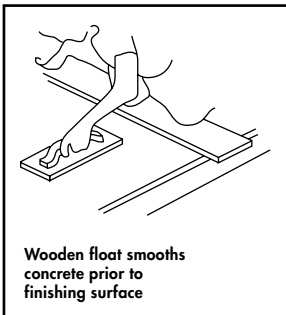

- For a heavier swirling imprint use a wooden float when the concrete is still slightly wet.
- A soft pattern of parallel lines can be created by dragging a soft brush across while the surface is still moist.
- All brush strokes can be made in the same direction, or each block between contraction joints can be brushed in opposite directions (fig 6) for a very desirable effect.
- An ordinary garage floor brush can be used to create extremely attractive wavy patterns in newly laid concrete. The wavy patterns add to the appearance and make the surface safer when wet.

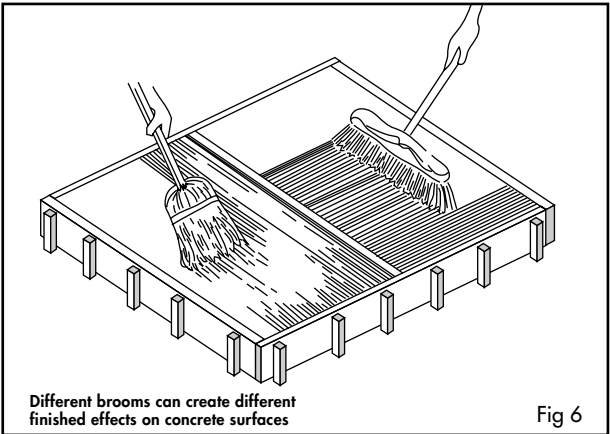

Letting the concrete cure

All concrete must be given time to cure. During this curing period, the concrete surface should be kept wet down by repeated hosing with a fine mist. Such a hosing down process should be done at least twice during any 24 hour period for about three days. Concrete poured in a basement, garage or other under-cover area can be left exposed. However, a guard rail should be placed around it to keep any child or animal from walking on the surface until it is dry. Concrete laid in the open air or direct sun should be covered with roofing felt or building paper during the curing period. This protective covering should be removed before the concrete is wet down.

Never attempt a big concrete job on an extremely hot day. Concrete will set extremely fast in direct sunshine. It is always better to wait until mid-afternoon even if this means working late in the evening.

Produced in association with



The Building Research Association of New Zealand

Please Note:

Whilst the advice and recommendations contained in this brochure have been produced with proper care, they are offered only with the objective of assisting those interested in home improvement projects and PlaceMakers does not accept responsibility for the advice, recommendations, etc. contained herein.

Information correct at time of printing: December 2002